

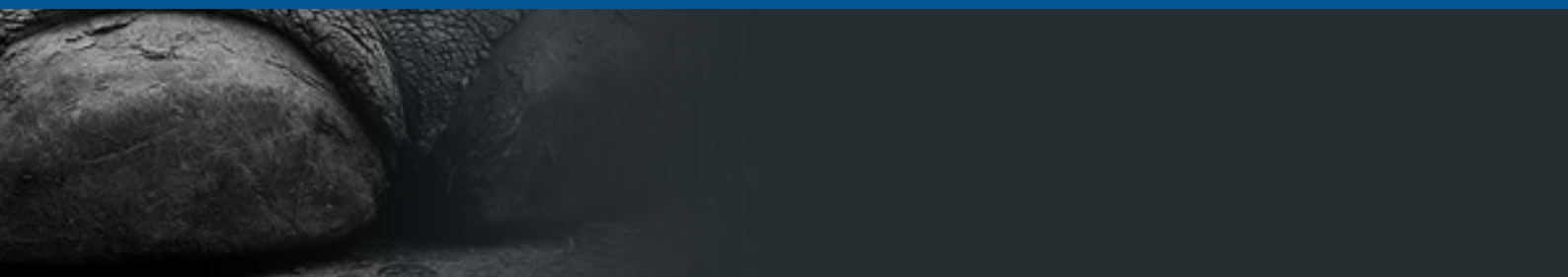

Motec camera monitor systems for container handling  
Applications for port and terminal logistics



## Reach stacker

### Assistance during manoeuvring, twistlock and rear view monitoring during container handling

The mobility of reach stackers is limited without camera technology. Motec cameras help the driver to see the rear area as well as the path ahead of him. The cameras help to assess distances and recognise persons or obstacles in the danger area well in time.

Additional cameras on the spreader support the driver and ensure the safe handling of containers by monitoring the position of the twistlocks. Consequently, it effectively prevents accidents and saves costs through fast operating procedures.



The cameras are mounted in such a way as to provide an optimum view onto the twistlocks.

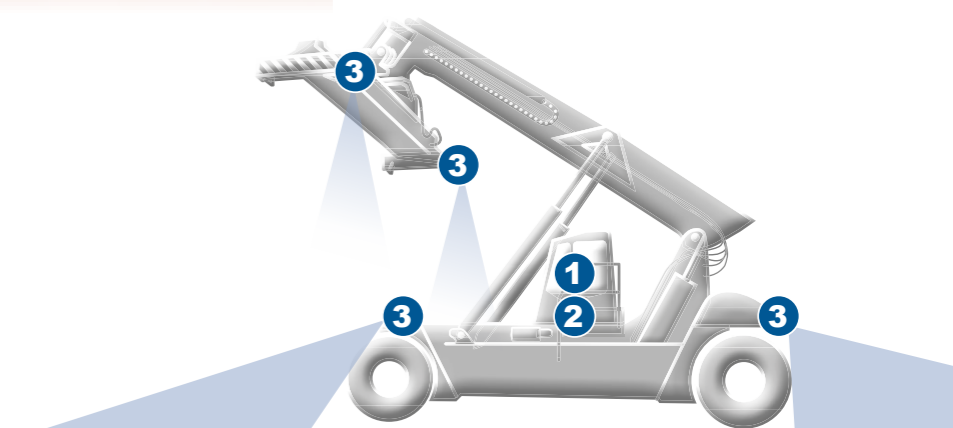

#### EXAMPLE OF SYSTEM: Reach stacker

- 1**  
**MD3100**  
 Heavy-duty 10,2" monitor
- 2**  
**MB1405 Quad**  
 Video control unit
- 3**  
**MC3000B**  
 Heavy-duty camera

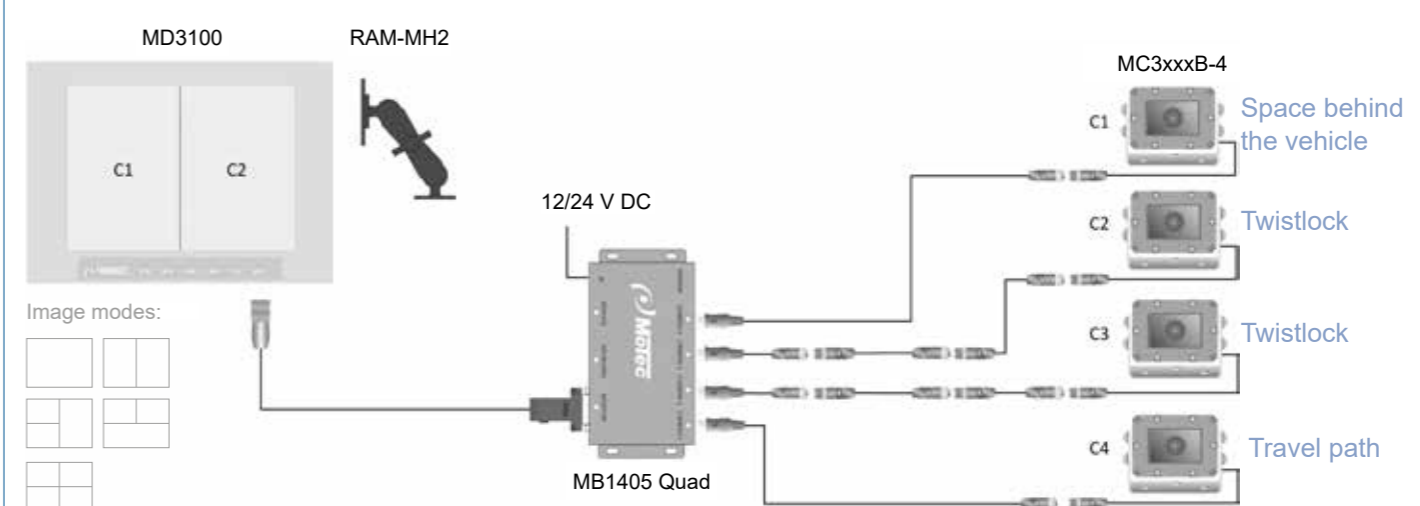

Optional with wireless transmission

## Empty container handler Container handling

The cameras support the driver when loading containers. The monitoring of the twistlocks enables a faster and more secure positioning.

The system can be extended by an automatically activated 180° rear view camera, which significantly facilitates manoeuvring processes.



Twistlock camera for safe container handling.

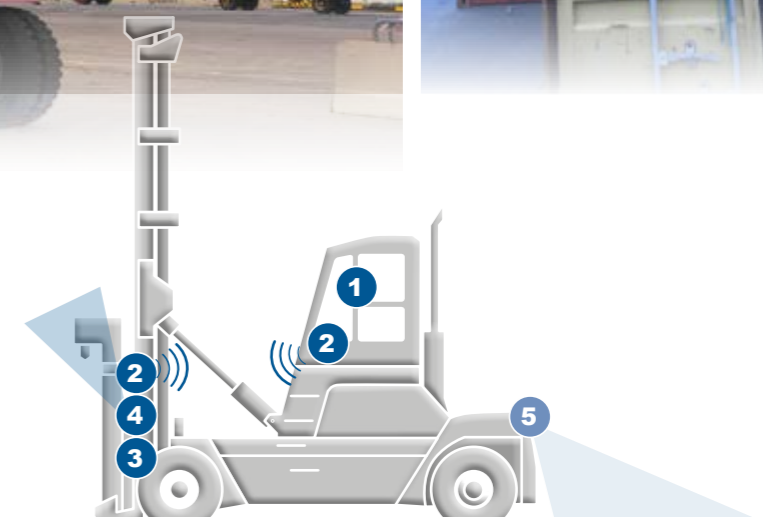
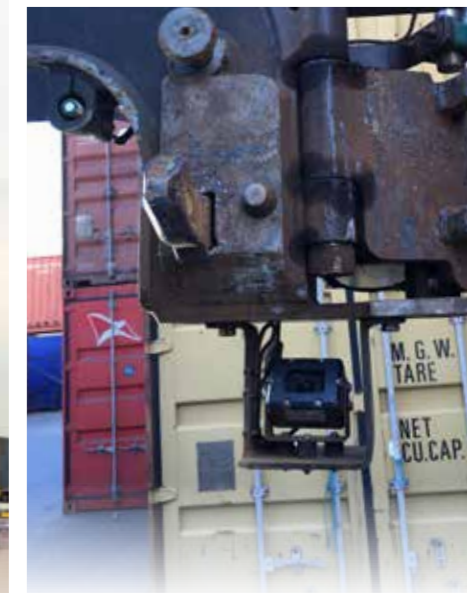

EXAMPLE OF SYSTEM:  
Empty container handler

- 1  
**MD3071A**  
Heavy-duty 7" monitor
- 2  
**Kit MVRD1000**  
Digital wireless system
- 3  
**Kit MVCU1400**  
Video control unit
- 4  
**MC3000B**  
Heavy-duty camera

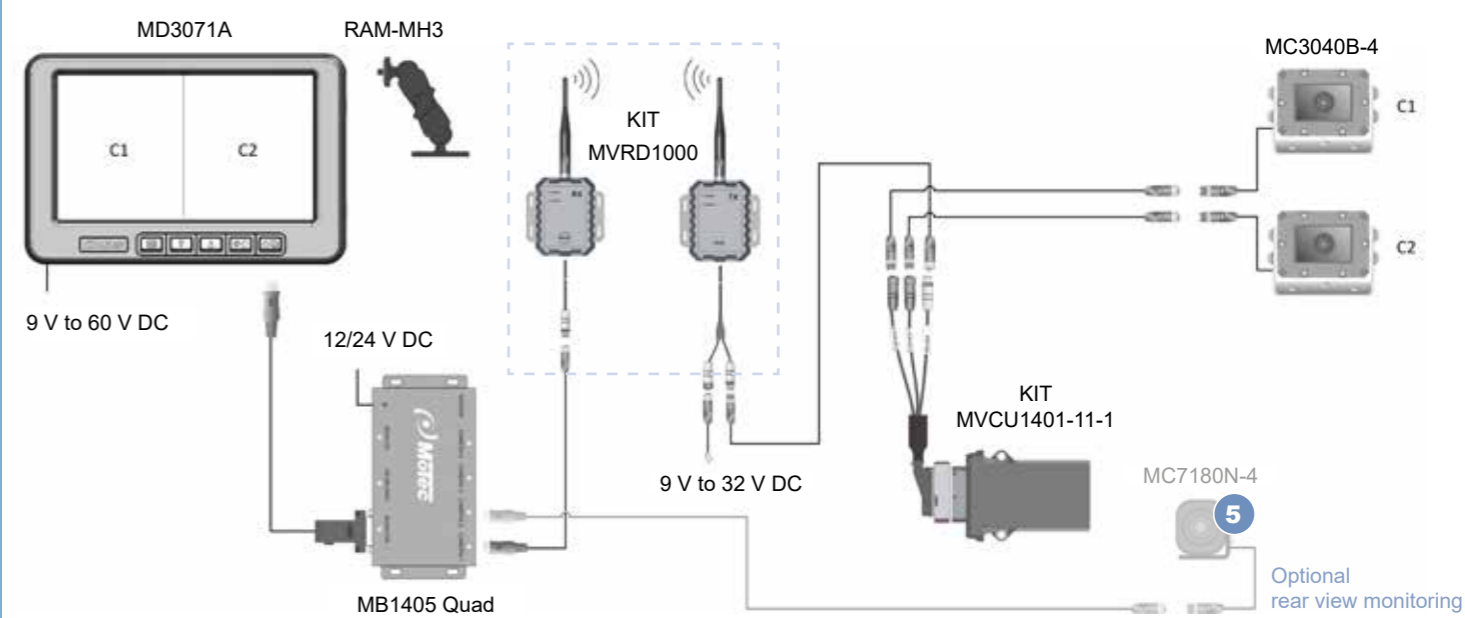

Optional rear view monitoring

## Straddle carrier

### Rear view monitoring and safe and fast handling of containers

At a height of up to 15 meters, the drivers have the best view forward and into the loading zone. However, the rear view is difficult and the mast cannot be positioned precisely from that height.

Motec cameras help the driver to see the rear and lateral area. The cameras help to assess distances and recognise persons or obstacles in the danger area well in time. 2 additional cameras provide an optimal view of the twistlocks.

The images are transferred to 2 monitors so that the driver can position the containers in a millimetre-accurate manner and can safely move around.

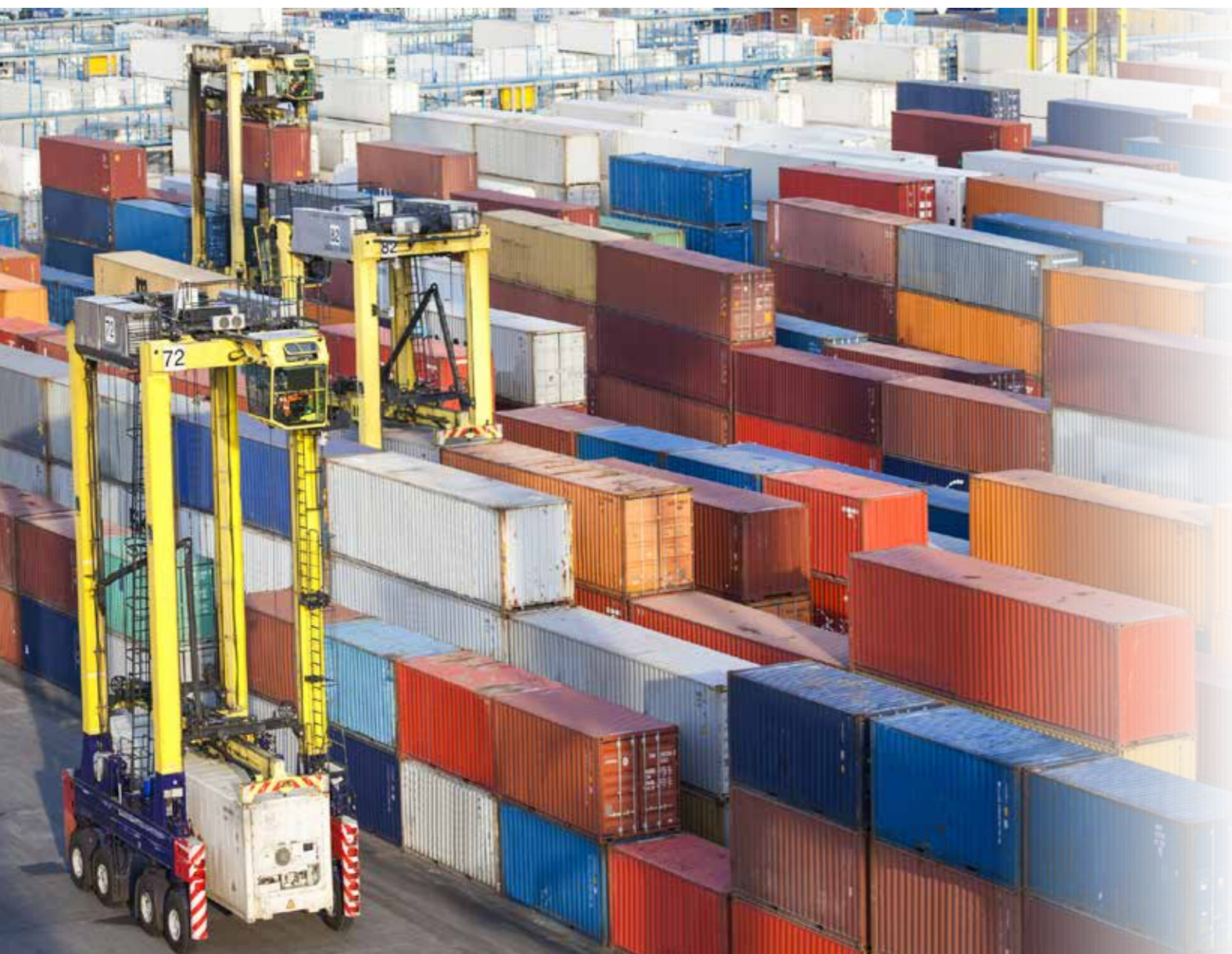

Lateral monitoring from great heights with Motec camera monitor systems.

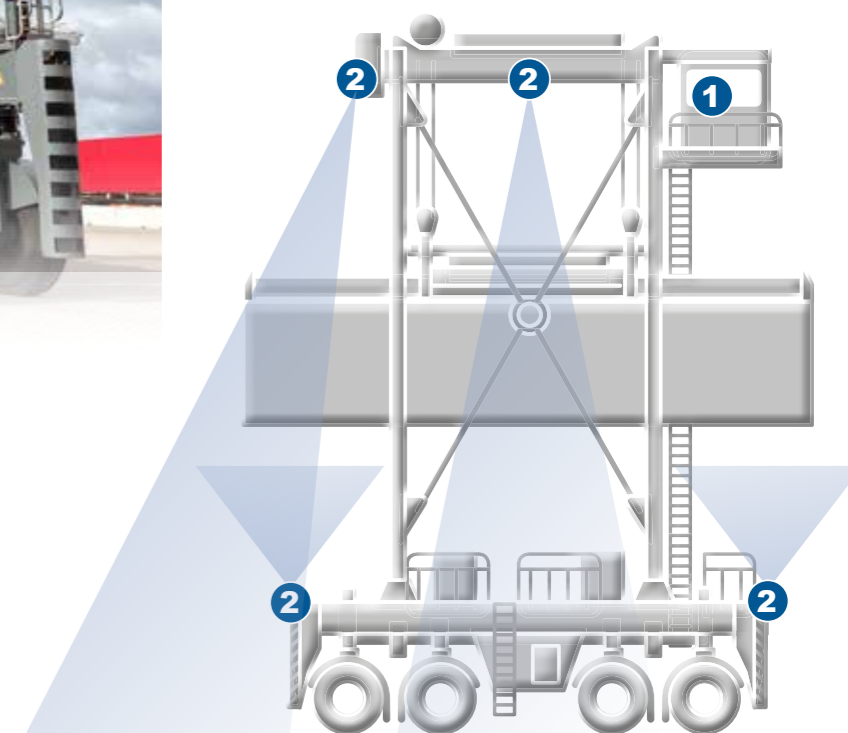

### EXAMPLE OF SYSTEM: Straddle carrier

**MD3072B Quad**  
Heavy-duty 7" monitor

**MC3000B**  
Heavy-duty camera

1

2

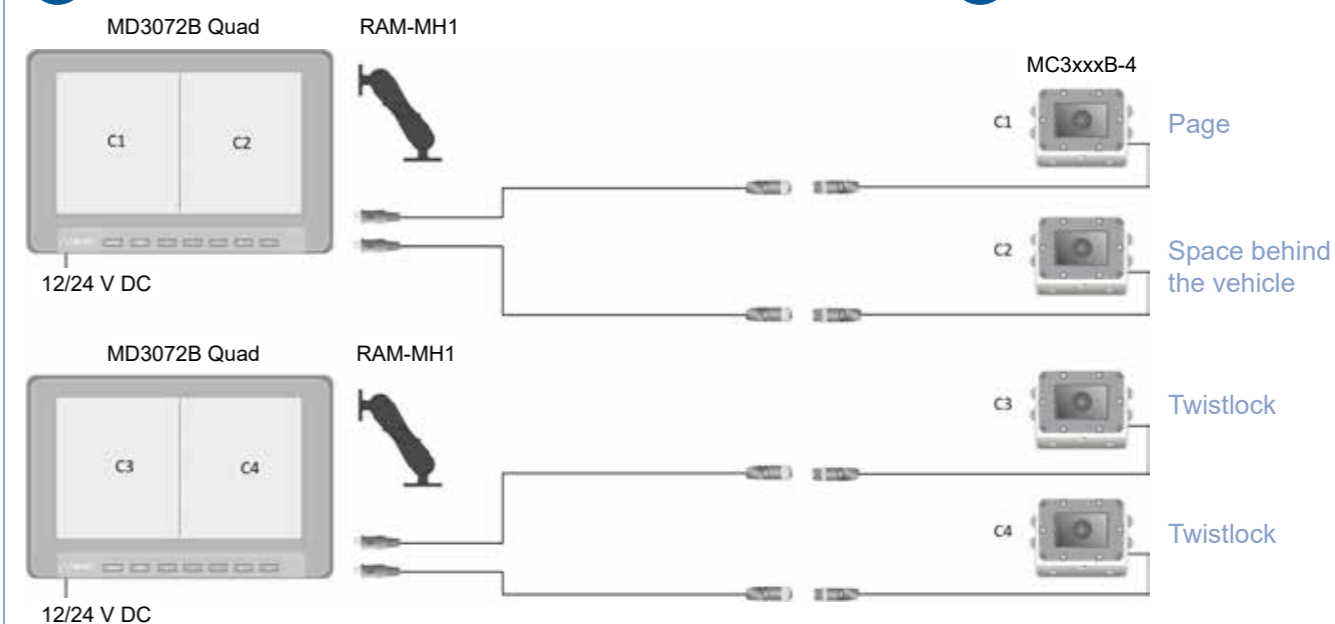

## Reach stacker Piggyback spreader

With the piggyback spreader, a reach stacker picks up the entire semi-trailer, which considerably simplifies the transport change between rail and road.

The cameras support the driver when recording the trailers. By monitoring the twistlocks, a faster and safer positioning is possible.

The system can be extended with an automatically activated reversing camera, which makes maneuvering much easier.



The cameras are mounted at the bottom of the 4 foldable lift legs. When gripping the swap bodies they allow an optimal view.

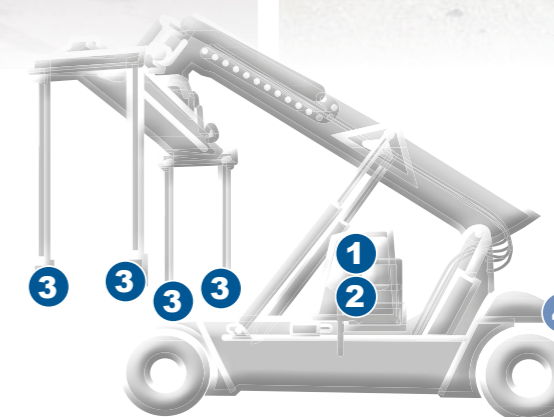

### EXAMPLE OF SYSTEM: Piggyback spreader

1 MD3100  
Heavy-duty 10,2" monitor

2 MB1405-Quad  
Video control unit

3 MC9150P  
camera with LED

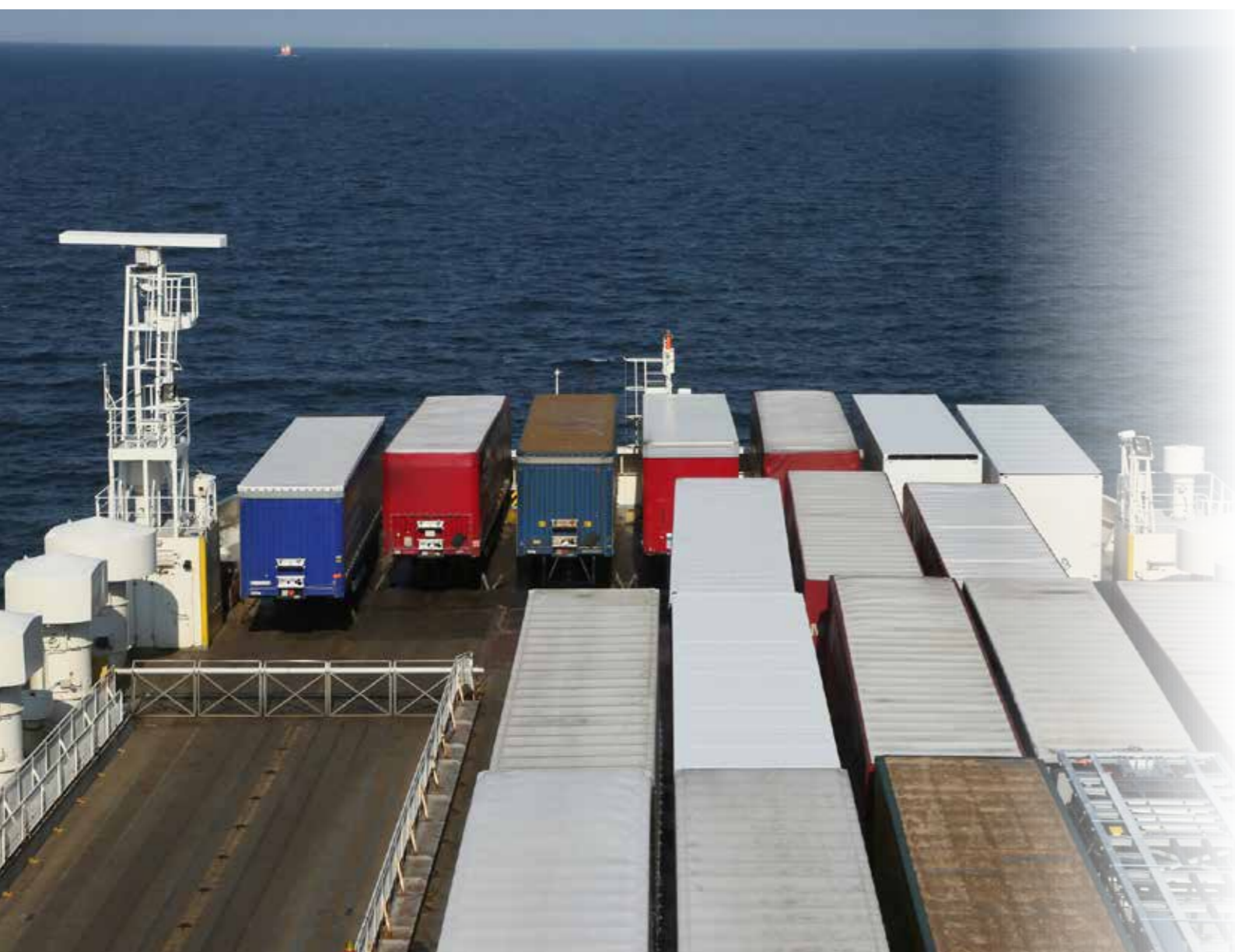
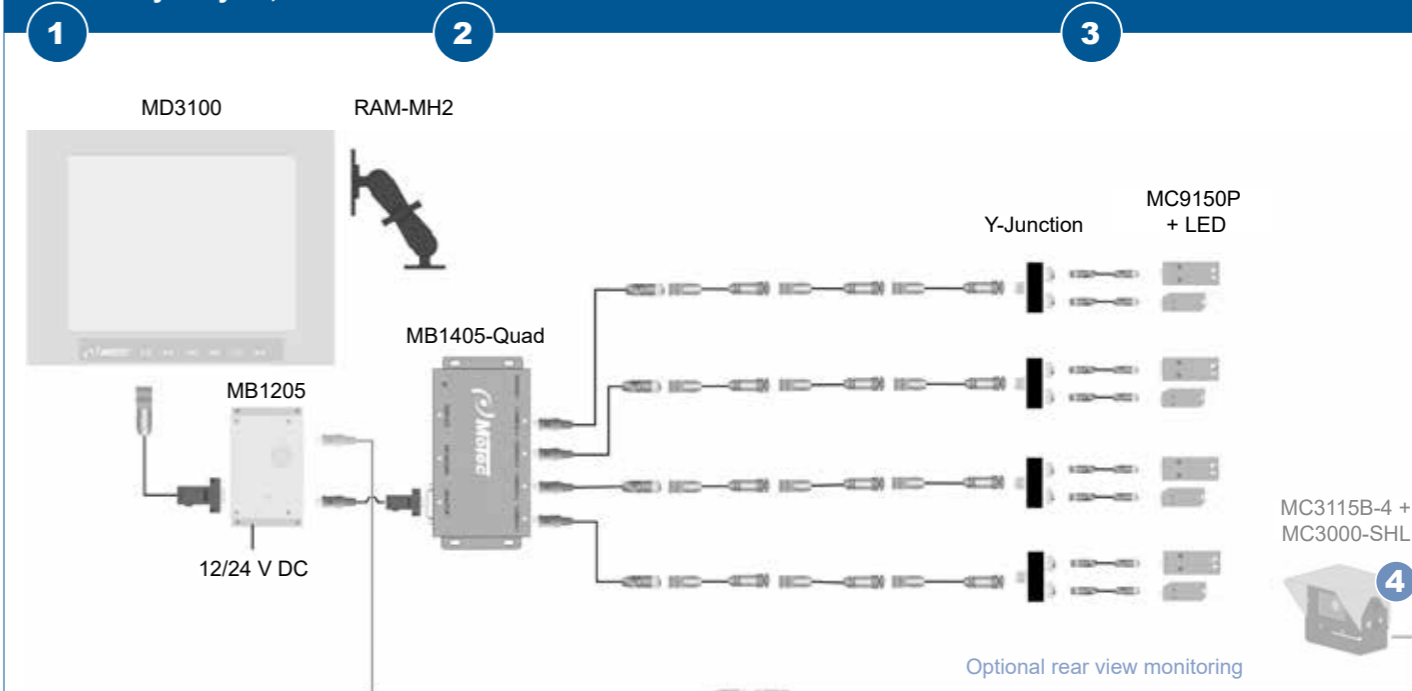

## Container bridge

### Container handling

Due to the design, the driver has only limited visibility to the rear and front of the vehicle. The risk of a collision with people, trucks or other obstacles is very high. An intelligent camera monitor system surveys the travel path in all directions and simultaneously displays up to 4 camera images on a single monitor. The image is transmitted via digital radio signals.

It is possible to switch the camera automatically between the front/rear area and the twistlocks.



Twistlock camera in use during container handling.

### EXAMPLE OF SYSTEM: Container bridge

**MD3100**  
Heavy-duty 10,2" monitor

**Kit MVRD1000**  
Digital wireless system

**MC3000B**  
Heavy-duty camera

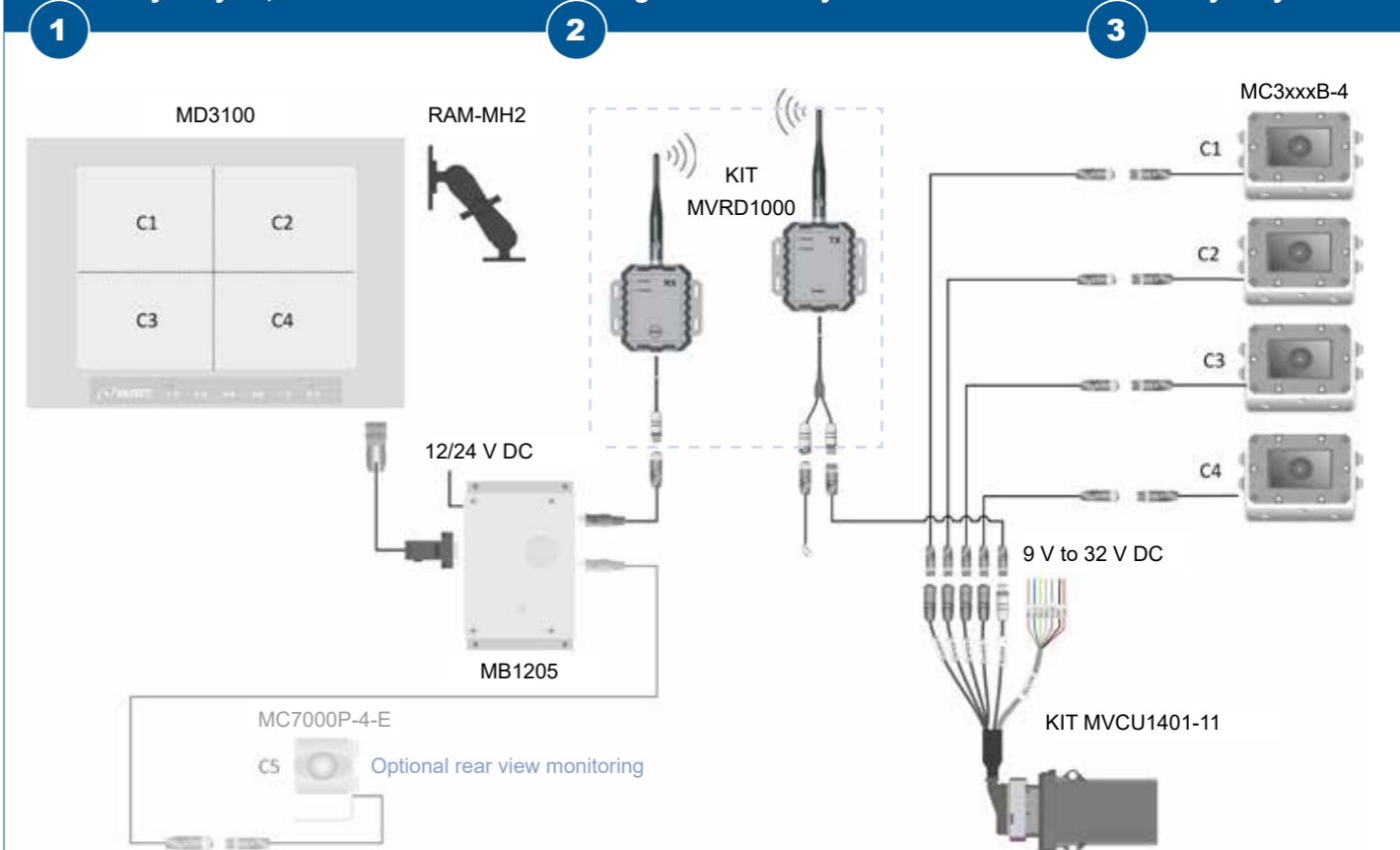

Optional image transmission via fibre optic cable (FOC) or twisted-pair converter.

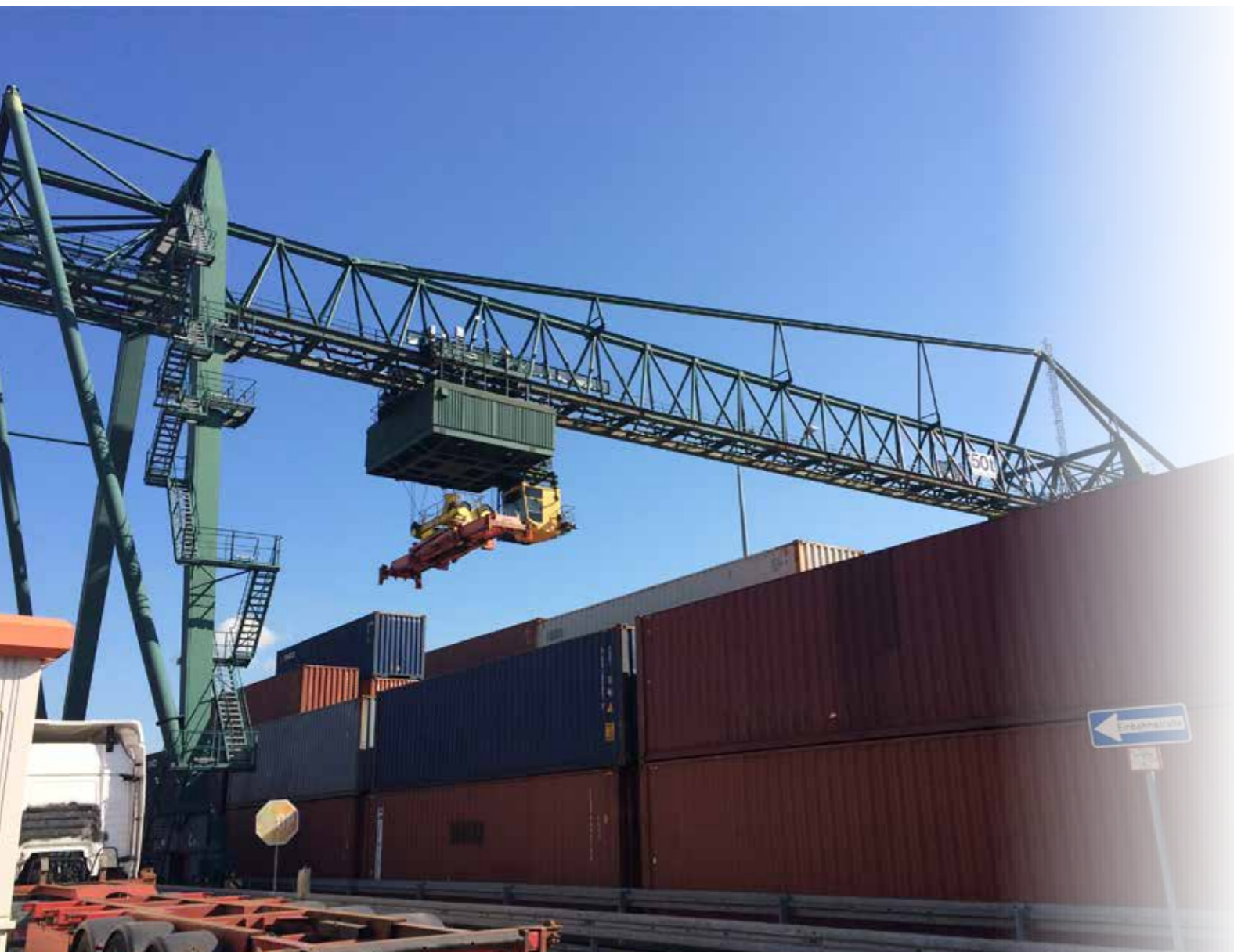

## Container and ship-to-shore cranes

### View on the travel path during container handling

The restricted field of sight of a crane operator for container and ship-to-shore handling equipment greatly raises the risk of a collision with people, lorries or other objects. An intelligent camera and monitor system with video control unit surveys the travel path in both directions and simultaneously displays up to 4 camera images on a single monitor.

The crane operator sees the travel path area and load in one direction of view. Dangerous situations can be seen early without twisting the upper body ensuring an ergonomic, efficient and cost-saving operation.



Rail-bound mobile harbour crane handling containers.



### EXAMPLE: Container crane

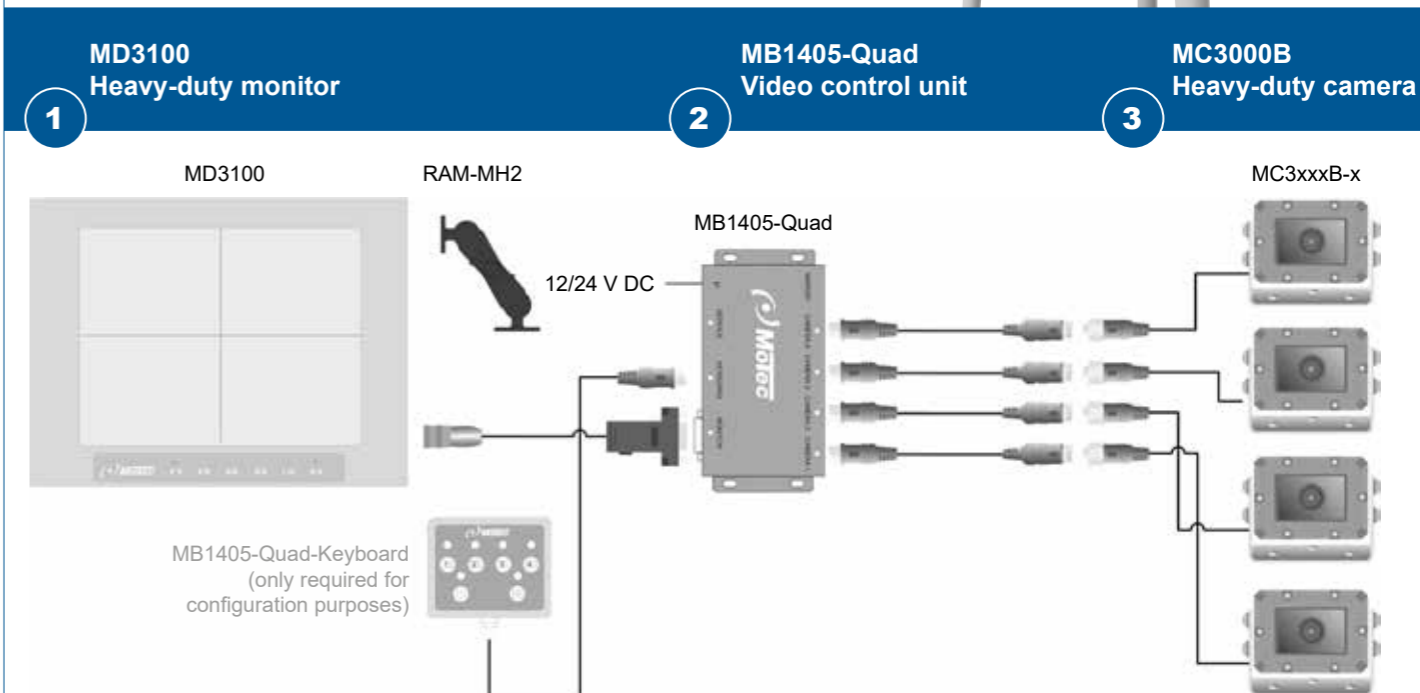

## Ship cranes

### Quick and safe material handling

Dock charges in the harbour are very high. Hence, the key factor in material handling is time. Camera and monitor systems support efficient working processes. Thanks to a motor zoom camera, the crane operator can constantly observe the loads even when they are placed in the hull. The zoom feature allows monitoring the danger zone during slewing.



Container handling with twistlock cameras increases the efficiency of ship cranes.

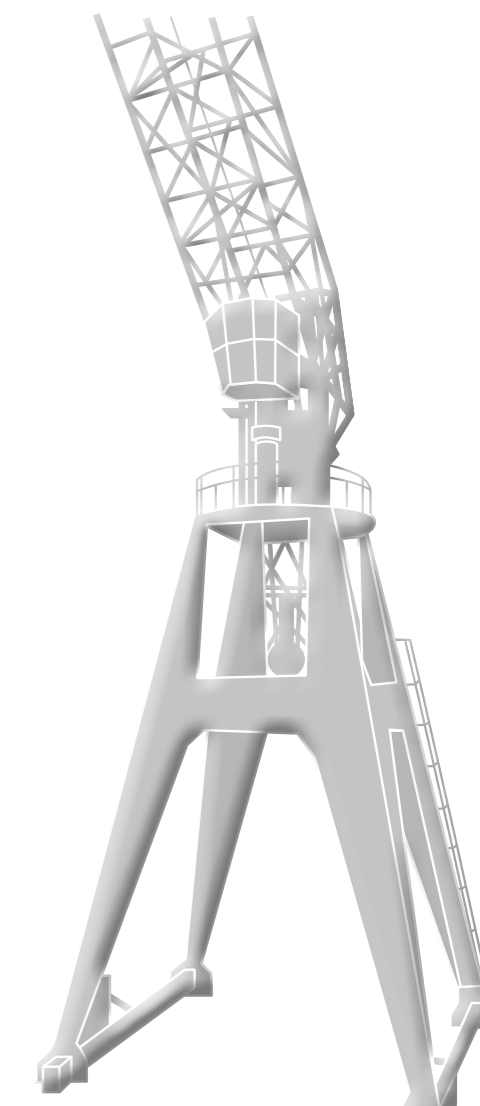

### EXAMPLE: Ship crane

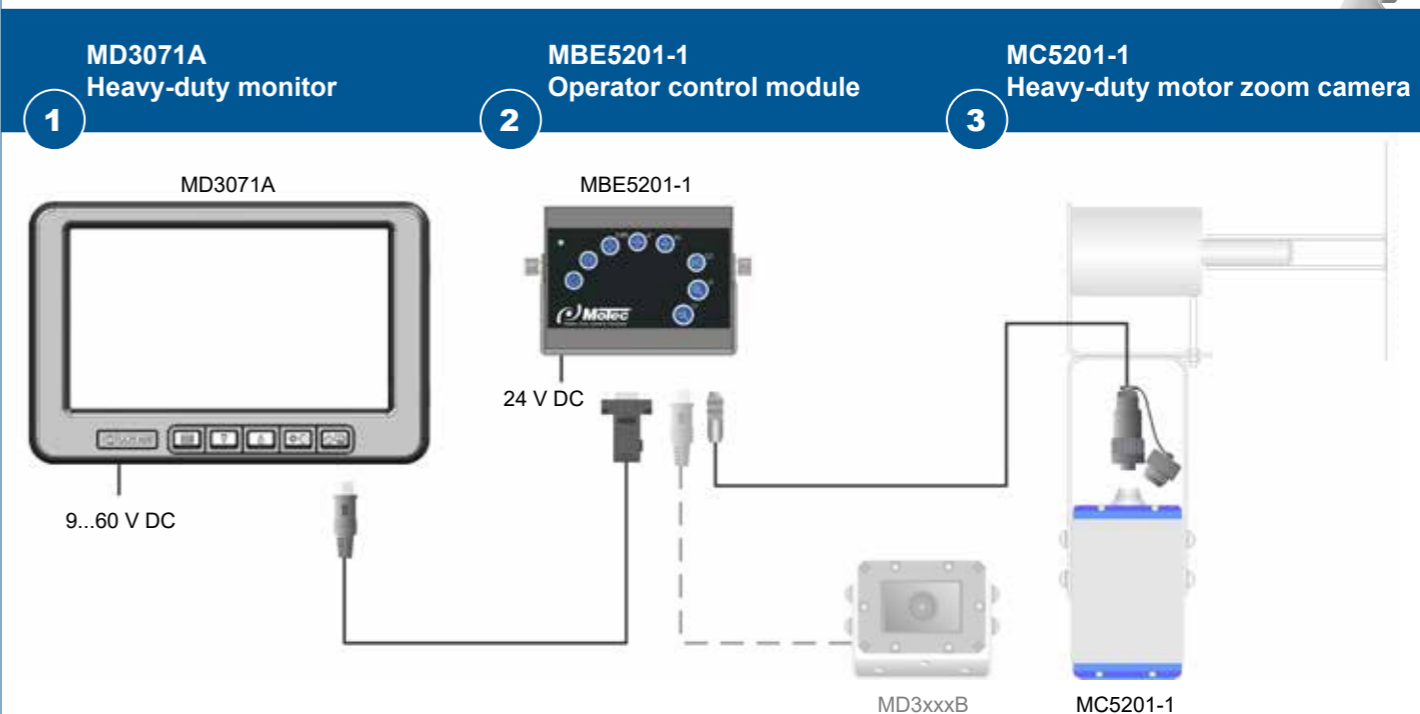



**Motec GmbH**

Oberweyerer Straße 21  
65589 Hadamar-Steinbach  
GERMANY

**Phone** +49 6433 9145-0

**Fax** +49 6433 9145-45

[motec.info@ametek.com](mailto:motec.info@ametek.com)

[www.motec-cameras.com](http://www.motec-cameras.com)

